



7700/9700

4-Spring Suspension Series

Maintenance Procedures



® U.S. and Canada

Advancing the Practical Application of Suspension Technology

Springfield, MO ■ (800) 654-8824 ■ (417) 862-5012
Fax (417) 862-2317 ■ www.hutch-susp.com

7700/9700 4-Spring Suspension Series - Maintenance Procedures



Warning

We strongly emphasize that each of the maintenance procedures that we will discuss have a significant safety purpose. Failure to maintain proper torque values on each of the suspension components can result in a failure of suspension components. Further, use of any visibly worn component can result in a failure. Any of these failures can result in loss of vehicle control and personal injury or death. Safety is the number one concern at Hutchens Industries. We urge you to follow the maintenance procedures set out in our video and in these written instructions.

The first maintenance check should be performed after an initial break-in period of about 1,000 miles. A visual inspection of all suspension components and attachment welds should be performed to reveal any obvious problems, such as cracks or unexpected wear.

During this “walk-around” it is essential to also check the torque on all suspension fasteners. In the course of the initial “shake down” period in which the components of the suspension “seat-in,” as much as 25% of the original clamp load on the bolted joints can be lost. After the parts of the suspension have worked together for a very short period of time, re-torquing the bolts is necessary to ensure that undue movement - which results in excessive suspension wear - does not occur.

During the first maintenance check, the trailer’s axle alignment should be examined and adjusted to comply with the Truck Trailer Manufacturers Association (TTMA) Recommended Practice #71-90. Alignment should also be checked following any maintenance or repair procedure performed on the suspension. Visual inspections and re-torquing are maintenance procedures that are performed every four months throughout the life of the trailer.

Begin each inspection with a review of the Hutchens torque decal (shown below) for the appropriate torque values for each suspension fastener. The oiled torque values in the first column are for new fasteners with lubricated threads. When you are installing new components, we recommend you lubricate the threads and use the torque values in this column. For maintenance checks on fasteners that have been in service, use the higher torque values in the dry thread column. It is important that you check all bolts and nuts to ensure that the recommended torque values are being maintained.

You cannot rely on your visual inspection to detect loose fasteners. **USE A TORQUE WRENCH!**

WARNING

SAFETY ALERT! (1) FOLLOW ALL TORQUE REQUIREMENTS. (2) DO NOT USE ANY COMPONENT WITH VISIBLY WORN OR DAMAGED THREADS. FAILURE TO FOLLOW THESE SAFETY ALERTS CAN LEAD TO LOSS OF VEHICLE CONTROL, PROPERTY DAMAGE, SERIOUS PERSONAL INJURY OR DEATH.

Hutchens Suspension Torque Requirements
9600-9700 Series (Decal Part Number 16086-01 Rev. G)

After an initial break in period, approximately 1000 miles, and at least every 4 months periodically thereafter, ALL bolts and nuts should be checked to insure that recommended torque values are being maintained.
Oiled torque values listed are for new fasteners with lubricated threads. It is recommended that new installations be performed with oiled fasteners. For dry threads which have been in service, use the higher torque values which are noted below.

| | OILED | DRY |
|---------------------------------------------------|------------|-----------|
| 1 1/8-7 (9600/9700 Rocker Bolt)..... | .590 lb-ft | 790 lb-ft |
| 1-14 or 1-8 (9700 Radius Rod Bolt)..... | .540 lb-ft | 720 lb-ft |
| 7/8-14 (Axle U-Bolts & 9600 Radius Rod Bolt)..... | .350 lb-ft | 470 lb-ft |
| 3/4-16 (Axle U-Bolts)..... | .310 lb-ft | 420 lb-ft |
| 5/8-18 (Radius Rod Clamp Bolt)..... | .130 lb-ft | 170 lb-ft |
| 5/8-18 (Spring Retainer Bolt)..... | .35 lb-ft | 50 lb-ft |

Hutchens Industries, Inc., P.O. Box 1427, Springfield, Missouri 65801-1427 Toll Free 1 (800) 654-8824

Hutchens Torque Decal Part No. 16086-01

This decal should be installed on the side of the trailer in a visible location. Decals can be obtained free of charge by contacting Hutchens Industries, Inc.

Now let’s look closely at the maintenance requirements for each of the suspension’s main component groups.

Axle Clamp Group and Springs

1. Check the torque on the U-bolt nuts by alternately tightening opposing corners of the clamp assembly. See Figure 1.
 - a. When using 7/8" - 14 U-bolts, the nuts should be torqued to a **dry** level of 470 lb-ft.
 - b. When using 3/4" - 16 U-bolts, the nuts should be torqued to a **dry** level of 420 lb-ft.

Fig. 1

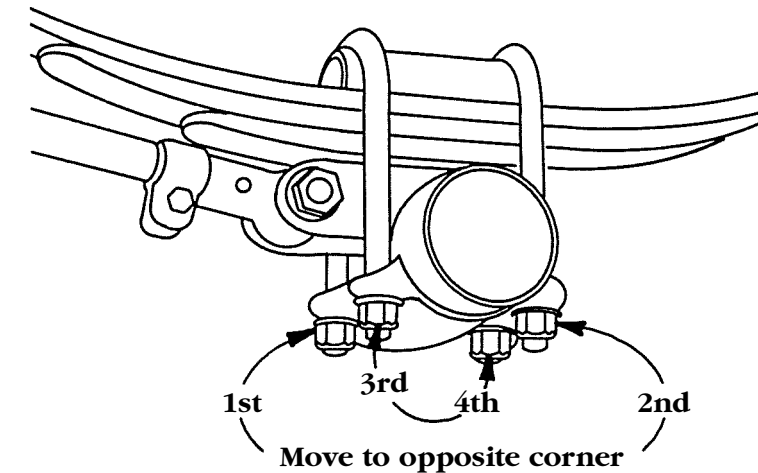

Always carefully inspect the spring and axle clamp components for any signs of wear or cracks, and replace if visible wear or cracks are present.

Radius Rods

- 2a. The 1" - 14 radius rod attachment bolts at the hangers and spring seats should be tightened to a **dry** level of 720 lb-ft of torque on both the adjustable and non-adjustable radius rods. See Figure 2.

Fig. 2

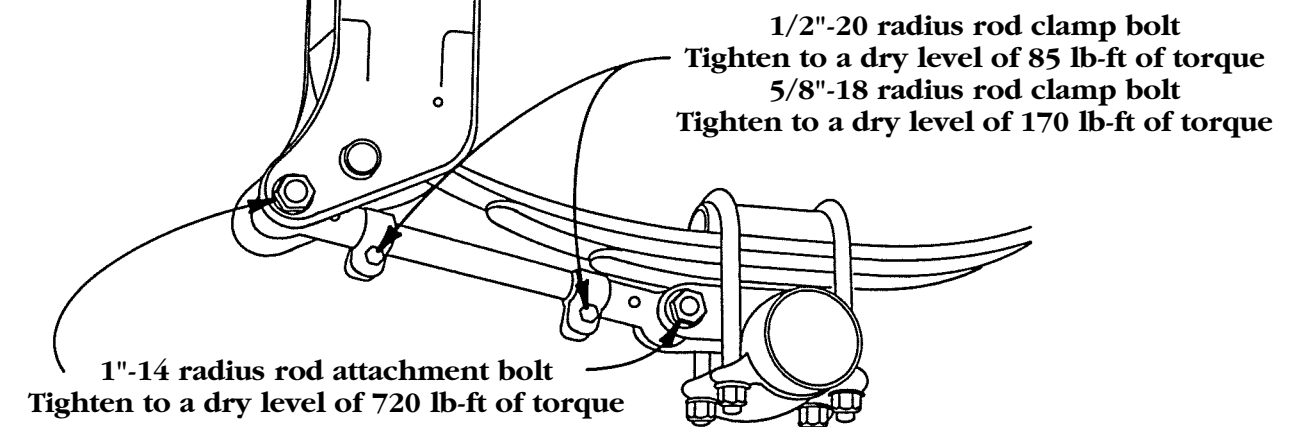

Loose operation of this bolt can result in wear requiring that new components be installed to avoid structural damage. During your visual inspection, if you observe any visible wear or loosening in the bushing, it is imperative that you immediately replace the radius rod bushing and bolt. Failure to replace these components will result in damage to the hanger, spring seat, and/or radius rod.

- 2b. Next check the 1/2" - 20 radius rod clamp bolt, which should be tightened to a **dry** level of 85 lb-ft of torque. The 5/8" - 18 radius rod clamp bolt should be tightened to a **dry** level of 170 lb-ft of torque. See Figure 2. If the clamp bolt has not been properly maintained, then wear between the radius rod screw and the eye end may be observed. If so, then the entire radius rod must be replaced. **Simply retightening or replacing the clamp bolt will not correct the problem.**

Rocker Busings

3. The recommended torque values for the rocker bushing clamp bolts are different for each model.
- If you are working on the 7700 model suspension, the 5/8" - 18 rocker step bolts should be tightened to a **dry** level of 170 lb-ft of torque. See **Figure 3a**.
 - If you are working on the 9700 model suspension, the single 1 1/8" - 7 rocker bolt should be tightened to a **dry** level of 790 lb-ft of torque. See **Figure 3b**.

Fig. 3a

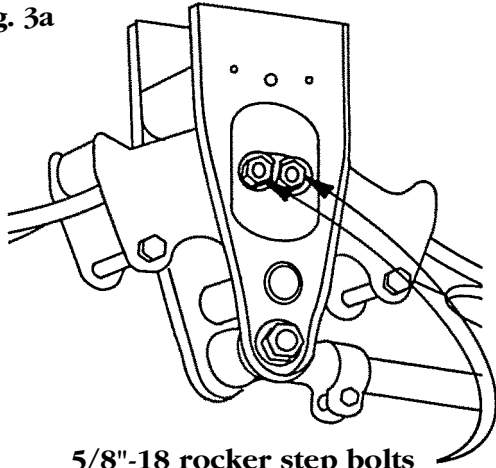

5/8"-18 rocker step bolts
Tighten to a dry level of 170 lb-ft of torque

Fig. 3b

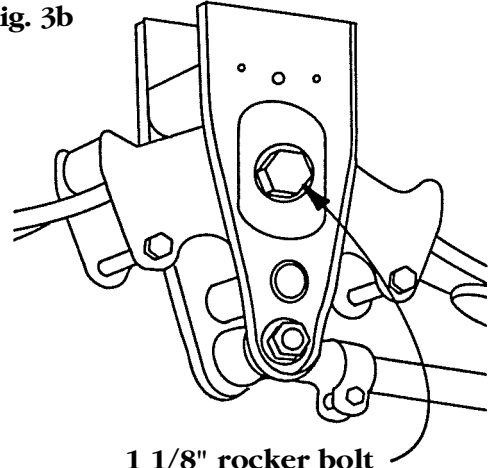

1 1/8" rocker bolt
Tighten to a dry level of 790 lb-ft of torque

During your check, if the bolts are loose a detailed inspection of the rocker is important to ensure that no structural damage has occurred. One way this can be done is by raising the trailer until the trailer weight is taken off the springs. If the rocker is displaced or if the joint is loose, then the rocker should be removed and the rocker and/or rocker bushing be replaced. Again, visually inspect the condition of all rocker/rocker hanger assembly components and replace if visible wear is present.

Hangers

4. Check all of the spring retainer bolts found in the rockers and rear hangers. A **dry** value of 50 lb-ft of torque should be maintained on all of these bolts. See **Figure 4**.

Fig. 4

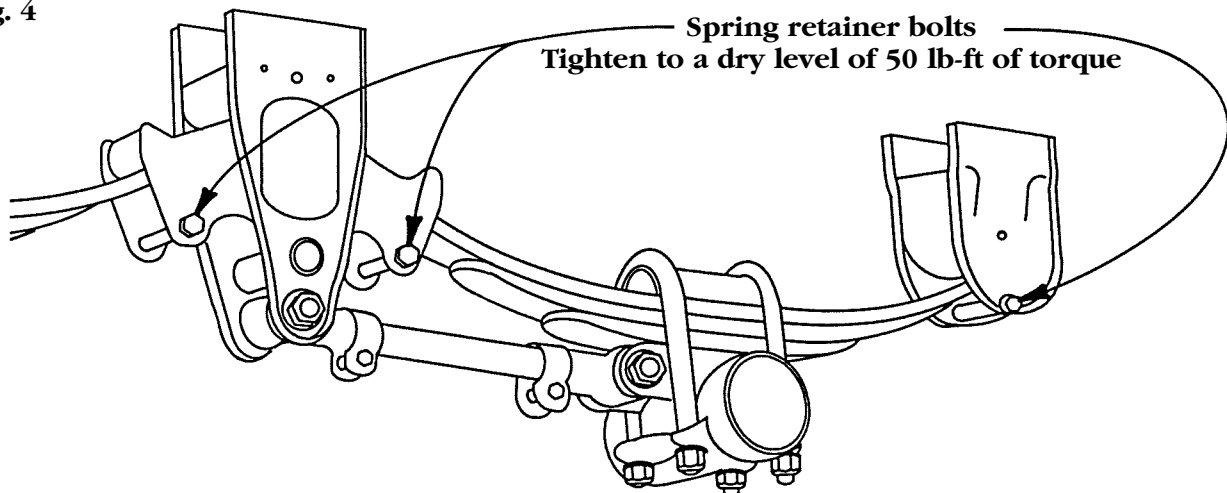

Loose fasteners that are allowed to operate for any period of time will result in irreversible suspension damage and possible loss of vehicle control. **Retightening a worn fastener will not correct a situation created by loose operation!**