

DWG No: PD900258-47495EBSC00

5 AXLE DOG EBS B CORE

drawn by: SRI KANNAN Dt: 17.08.15

Not to scale
Dwg size: A3
Revision No: 00
Date:

Revision description:

© This drawing remains the sole property of Gough Transport Solutions. Reproduction in any way is not permitted without written acceptance.

SARN
47495CS

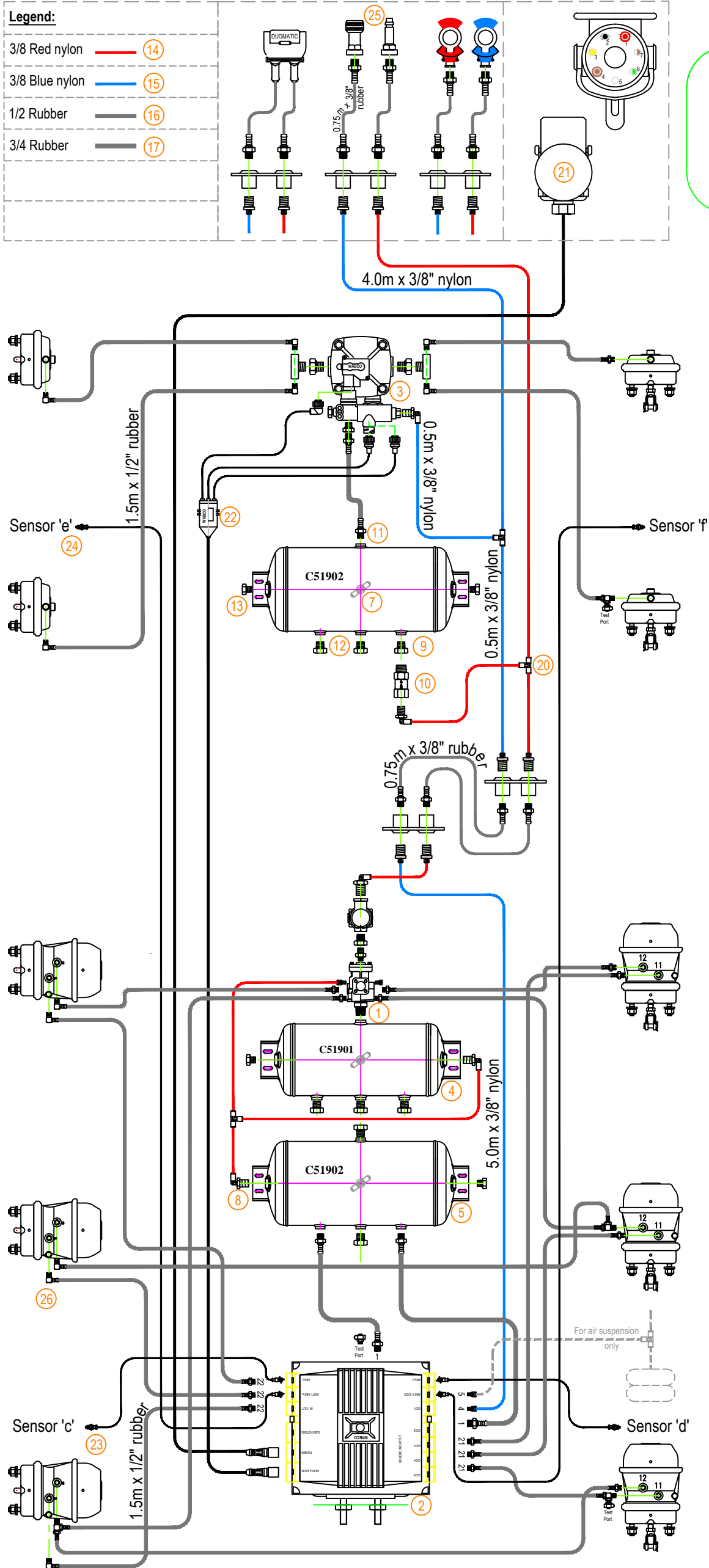

Be aware of:

- Any change in plumbing and / or electrical circuit may result in malfunction or non compliance to ADR
- Not to exceed any service / control line length than what mentioned in the schematic
- Strictly follow the main ECU modulator installation instruction from WABCO (attached with this booklet)
- Schematic shows ECU facing forward, but if mounted facing rearward, then sensors should be mirrored accordingly
- If the trailer has lift axle(s), do not connect 'c' & 'd' wheel speed sensors to lift axle(s), rather connect to any non lift axle
- Commissioning an End Of Line by an authorized personnel after installation is mandatory
- Plug all unused ports
- GTS cannot be held responsible for consequences faced due to failing to follow the above

BILL OF MATERIALS

S No	Product	Qty	Description
1	100305520-C02	1.00	Valve assembly Wabco SBVC - config 02
2	480-102-080-0-C03	1.00	Valve assy Wabco TEBS MV config 03
3	480-207-202-0-C02	1.00	Valve assy Wabco EBS relay config 02
4	C51901	1.00	Air brake tank 246mm dia 25L
5	C51902	2.00	Air brake tank 310mm dia 48L
6	C51663	6.00	Gasket rubber air tank mtg
7	221121	3.00	Drain cock 1/4m
8	222062PS	3.00	Elbow swivel 1/2 m x 3/8 t/od p/c
9	234680	1.00	Reducing bush 3/4m 1/2f
10	5003980	1.00	SC3 Single check valve 1/2 m/f
11	C52011	3.00	Conn 3/4m x 3/4 hose barb
12	204514	7.00	Pipe plug hex 3/4ml steel
13	238822	4.00	Pipe plug sq 1/2" m
14	3023-71	15.00	Nylon tube j844b red 3/8 (152.4m)
15	3023-83	10.00	Nylon tube j844b 3/8 blue (152.4m)
16	ABH12	25.00	Rubber air brk hose j1402 1/2" (76.2m)
17	3023-300	6.00	Rubber hose 3/4 id (152m)
18	C50888	32.00	Hose clamp 11-22mm
19	C50889	6.00	Hose clamp 17 - 32mm
20	205106P	3.00	Tee union 3/8x3/8x3/8 t/od pc
21	449-273-120-0	1.00	Power cable front - male
22	449-429-130-0	1.00	EBS E Modulator cable with socket 13m
23	449-723-030-0	2.00	EBS E WSS cable with socket 3m
24	449-723-100-0	2.00	EBS E WSS cable with socket 10m
25	BCD-B01 (OR)	1.00	Bayonet coupling assembly (OR)
	DCD-B01 (OR)		Duomatic coupling assembly (OR)
	GCD-B01		Gladhand coupling assembly
26	BF-5A-dog-drum-I01 (OR)	1.00	Booster fitting 5 Axle dog drum imperial (OR)
	BF-5A-dog-drum-M01 (OR)		Booster fitting 5 Axle dog drum metric (OR)
	BF-5A-dog-disc-I01 (OR)		Booster fitting 5 Axle dog disc imperial (OR)
	BF-5A-dog-disc-M01		Booster fitting 5 Axle dog disc metric
27	PD900258-47495EBSC00	1	Drawing for 900258-47495EBSC00