



Pro-forma High-Productivity Motor Vehicle Permit to Exceed Length Limits

ISSUED UNDER Land Transport Rule: Vehicle Dimensions and Mass 2002 (the Rule)

Company Name: *FONTERRA LTD*

TSL Number: *0209813*

is hereby authorised to use the vehicle combination specified in Schedule 1:

Schedule 1

Truck = GMF322

Trailer/s = U621C, 7A9E10014C1023096, 7A9E10016C1023097, 7A9E10018C1023098

for **High Productivity Motor Vehicle** trips indefinitely, over the route described below, subject to the conditions and restrictions in this permit (Note: this is a permit to exceed length limit dimensions only)

Route Description:

General access to NZ Roads at the axle, axle set and gross mass limits in the relevant tables limits in *Schedule 2 part A general mass limits of the Rule*.

NOTE: Pro-forma vehicles are overlength vehicles that are eligible to have general access to the whole road network at standard vehicle mass limits, because they have been designed within existing swept path and safety performance parameters.

Pro-forma vehicles are treated as standard motor vehicles for all other requirements and enforcement actions except for the length dimensions that are identified on this permit.

CONDITIONS:

- The dimensions of the vehicle including the load must not exceed any of the length limits shown below. Refer to table 4.1 in the Rule for dimensions not shown here.

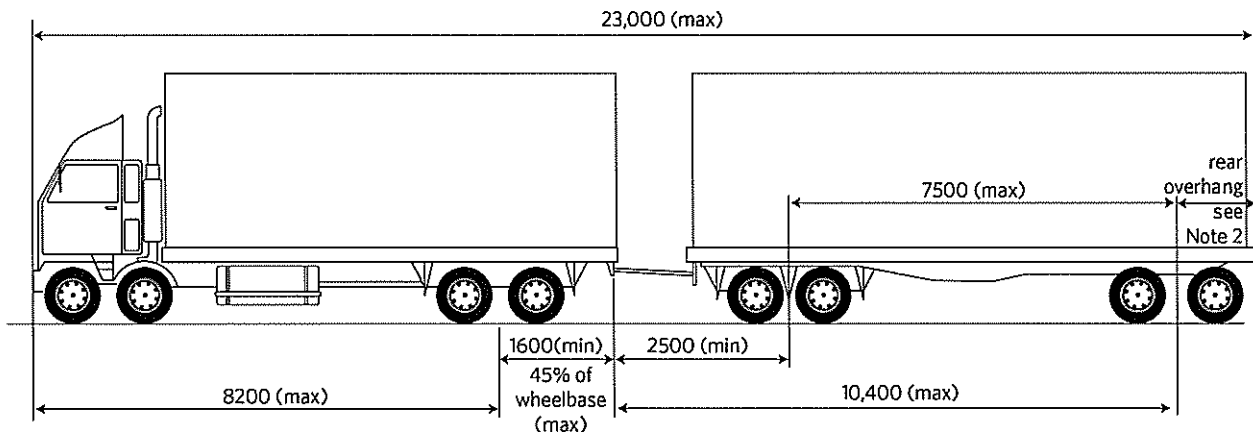

Note 1: Axle sets may be replaced with alternative axle sets at the same axis points

Note 2: Maximum rear overhang is the lesser of 4300mm or 50% of the forward distance

- Roll Stability Control (RSC): The trailer(s) must have roll stability control fitted and active; that is EBS brakes with the roll stability function turned on. Alternatively a trailer without EBS brakes can operate with a minimum operational Static Roll Threshold (SRT) of 0.4g. Documentation must be carried to demonstrate that RSC is active, or the operational SRT limits, to enforcement officers.
- This permit is void and of no effect if any of its conditions or special conditions are breached or if the permit is altered or mutilated without authority.
- This permit must be carried in the towing vehicle when operating as an HPMV, and must be surrendered for inspection on the demand of any enforcement officer, or an authorised agent of the NZ Transport Agency or a road controlling authority.



Special Conditions:

There are no special conditions.

Allowance to carry certain overwidth loads:

Exemption from specified requirements of Land Transport Rule: Vehicle Dimensions and Mass 2002 PURSUANT TO section 166 (1) of the *Land Transport Act 1998* ['the Act'], and being satisfied on those matters in section 166 (2) of the Act, I, Lisa Wamoana, Permits Officer, acting under delegated authority, exempt the motor vehicles specified in Schedule 1 of this permit from the requirements of *Land Transport Rule: Vehicle Dimensions and Mass 2002* listed in Schedule 2 subject to the conditions in Schedule 3.

Schedule 2: *Exempted Requirements:* - Clause 4.1(1) with regards to the width requirement in table 4.1 when carting loads described in Clause 6.2(1) and Clauses 5.2(10) and 6.1(3)

Schedule 3: *Conditions:* 1) The vehicle must comply with sections 6 and 7 of the Rule.

Note: This exemption allows pro-forma overlength HPMV vehicles to be treated as 'a standard motor vehicle' when carting wool, hay, concrete pipes with a minimum nominal bore of 300mm that are loaded transversely on the deck, to a maximum of 2.7m wide, or an indivisible load. For clarification, travel time restrictions will be in place unless the vehicle has a swept path certificate issued under *Clause 6.6(11)*.

Authorised Issuing Officer

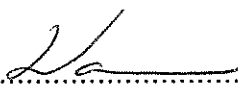
.....
Lisa Wamoana

(Signature)
(Name)

Permits Officer
(for) NZ Transport Agency
OPIA

(Designation)
(Controlling Authority)
(Location)

17 October 2012

(Permit Dated)

Note:

- NOT HIGHER MASS** – In the event that the vehicle **is not** operating on an HPMV higher mass permit then this document is a complete High-Productivity Motor Vehicle Permit, issued under section 5.2(3) of the Rule.
- HIGHER MASS** – In the event that the vehicle **is** operating on an HPMV higher mass permit then this document constitutes part of a High-Productivity Motor Vehicle Permit issued under section 5.2(3) of the Rule, with the other part of that Permit being any valid Permit to Exceed Mass Limits issued for the vehicle. Further information about Permits to Exceed Mass Limits can be found on the NZ Transport Agency website, <http://www.nzta.govt.nz/>.
- This permit does not exempt the holder from complying with all other acts, regulations and other laws (including those relating to certificate of loading and road user charges). Breaches of the conditions of the permit may constitute offences in the terms of the Land Transport Act 1998.

Fees Payable:

Permit Issuing Fee (As specified in Schedule 4A of the Heavy Motor Vehicle Regulations 1974)	\$54.55
GST	\$ 8.18
Total	\$62.73